

## Press Release

# S-89713 Dual CMOS Op-Amp has Instrumentation Amplifier Capabilities

The dual CMOS Op-Amp S-89713 is extending Seiko Instruments Mini Analog Series as a new member with a bunch of outstanding parameters. The input offset voltage of this zero-drift amplifier is only a mere 10 $\mu$ V maximum because of the applied auto-zero operation. With this very low input offset and an almost negligible input offset drift of typical  $\pm 0.1\mu\text{V}/^\circ\text{C}$  this amplifier lends itself to applications requiring high gain for very small signals. This can be output from sensors, precision resistance for measurement purposes (shunts), strain gauge or other measurement bridge and a multitude of other signal sources. The supply voltage range is 2.65V to 5.5V. Since the amplifier is made in CMOS, input- and output-signals can cover the full supply range. Current consumption is typically 165 $\mu$ A per Amplifier. The internal phase compensation does not require an external capacitor. Other remarkable characteristics are the common mode rejection ratio (CMRR) of typical 130dB and the gain bandwidth product (GBP) of 240 KHz. The dual amplifier die is packaged in an 8-pin package either a SNT-8A of 2.0x2.5x0.5mm<sup>3</sup> or a TMSOP-8.

### Application example for S-89713B

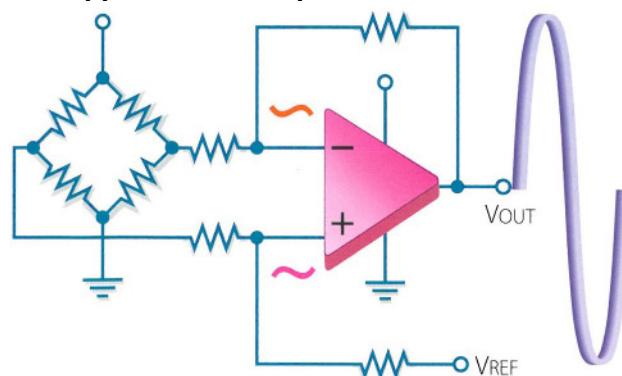

## Contact:

**Paul Krisam**, Technical Sales Support Manager, Components Department  
Seiko Instruments GmbH, Siemensstraße 9, 63263 Neu-Isenburg, Germany  
Tel.: +49 6102 297 143, Fax.: +49 6102 297 50 143  
Mobile: +49 172 6396 127, eMail : [Paul.Krisam@seiko-instruments.de](mailto:Paul.Krisam@seiko-instruments.de)  
Website : <http://www.seiko-instruments.de>